

# TGH Series

## 120 and 200 Watt SOT227Package Thick Film Power



Due to their non-inductive design, these resistors are ideally suited for high-frequency and pulse-load applications. Available in 120- or 200-watt sizes, this resistor is designed for direct mounting onto a heatsink. Popular applications include variable speed drives, power supplies, control devices, telecom, robotics, motor controls, and other switching designs.



### CHARACTERISTICS

<b>Heat Sink</b>	Nickel-plated copper
<b>Contacts</b>	Nickel-plated copper
<b>Substrate</b>	Al2O3 (96%)
<b>Molding Compound</b>	High-performance epoxy, compliant to UL94-V0
<b>Terminal Nuts</b>	American standard 303 stainless steel
<b>Resistance Range</b>	0.1Ω to 1MΩ
<b>Tolerance</b>	±5%; other tolerances available on request
<b>Temperature coefficient:</b>	±250ppm (at +105°C ref. to +25°C)
<b>Max. Working Voltage</b>	500V (1000V, not to exceed rated wattage using $\sqrt{P \cdot R}$ .)
<b>Power Rating at 85°C</b>	120W (see derating)
<b>Partial Discharge</b>	up to 2,000Vrms/80 pC
<b>Voltage Proof</b>	Dielectric Strength up to 4,000V DC against ground
<b>Heat Resistance to Cooling Plate</b>	$R_{th} < 0.35$ K/W
<b>Capacitance/Mass</b>	45pF
<b>Working Temp. Range</b>	-55°C to +155°C
<b>Max. Torque for Base Plate (static)</b>	1.5 Nm
<b>Max. Torque for Contacts (static)</b>	1.3 Nm. M4 screws (not included)
<b>Derating (thermal resistance)</b>	2.86W/°K (0.35°K/W)

### Derating

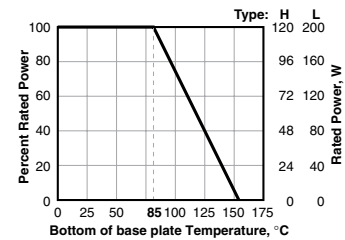

Best results can be reached by using a thermal transfer compound with a heat conductivity of better than 1W/mK

### Configurations

(per package)

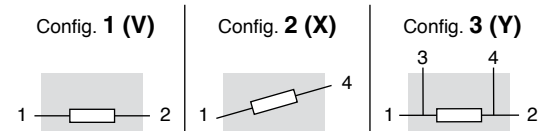

### PERFORMANCE DATA

Test Method	$\Delta R$
<b>Moisture Resistance</b> MIL-Std-202, Method 106	(0.5% + 0.001W) max
<b>Thermal shock</b> Mil-Std-202, Method 107, Cond F	(0.3% + 0.01W) max
<b>Terminal Strength</b> MIL-Std-202, Method 211, Cond A (pull test) 2.4N	(0.2% = 0.01W) max
<b>Vibration, High Frequency</b> MIL-Std-202, Method 204, Cond D	(0.2% + 0.01W) max
<b>Life</b> 20 years (120,000 hours) Operating failure rate of $8.3 \times 10^{-7}$ fail/hour.	

Requirements to be achieved under the following conditions:  $T_{amb}=25^{\circ}C$ ,  $T_{HS}=70^{\circ}C$ ,  $P_{applied}=P_n$

(continued)

# TGH Series

## 120 and 200 Watt SOT227 Package Thick Film Power

### DIMENSIONS

(iin./mm)

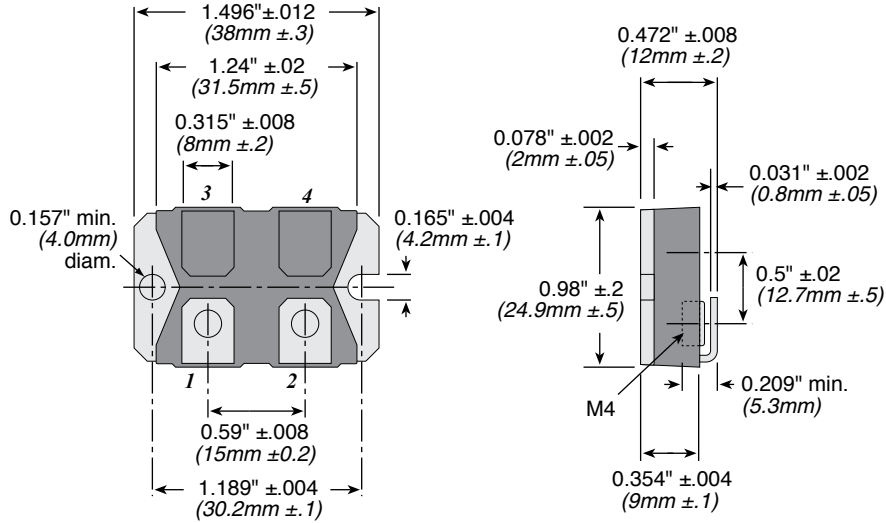

### ORDERING INFORMATION

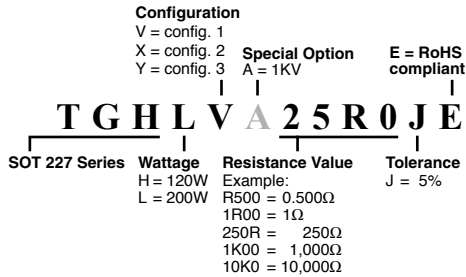

#### Standard Part Numbers

Ohms	120 Watt TGHH	200 Watt TGHL
0.1	TGHHVR100JE	TGHLVR100JE
0.5		TGHLVR500JE
1	TGHHV1R00JE	TGHLV1R00JE
5	TGHHV5R00JE	
10	TGHHV10R0JE	TGHLV10R0JE
25		TGHLV25R0JE
33	TGHHV33R0JE	TGHLV33R0JE
50	TGHHV50R0JE	
100	TGHHV100RJE	TGHLV100RJE
150	TGHHV150RJE	TGHLV150RJE
500	TGHHV500RJE	TGHLV500RJE
680	TGHHV680RJE	TGHLV680RJE
1K	TGHHV1K00JE	TGHLV1K00JE
5K	TGHHV5K00JE	TGHLV5K00JE
10K	TGHHV10K0JE	TGHLV10K0JE

### THIS PRODUCT IS DESIGNED FOR USE WITH PROPER HEATSINKING.

Maximum base plate temperature of the resistor must be monitored and kept within specified limits to establish the power rating. Best technique is to attach a thermocouple to the side of the base plate of the resistor. Temperature of plastic housing or heat sink cannot be used to establish rating of the resistor.